

JETINOX

SURFACE PUMPS - SELF-PRIMING

- Self-priming
- Excellent priming capacity
- Stainless steel pump body
- Many possible uses for the residential market
- Quite operation
- Compact dimension



DESCRIPTION

The self-priming pumps in the JETINOX range combine the advantages and practical features of centrifugal pumps with the functionality of self-priming pumps, as well as quality performance. The Venturi pipe system on these pumps guarantees optimal hydraulic performance and impressive suction capacity, maintaining priming even in the presence of air or gas bubbles trapped in the water.

APPLICATIONS

- Lifting and distribution of water in domestic systems in continuous or intermittent operation
- Pressurization systems
- Washing, garden irrigation, supply to fountains, transfers.
- Lifting from wells or tanks

PERFORMANCE

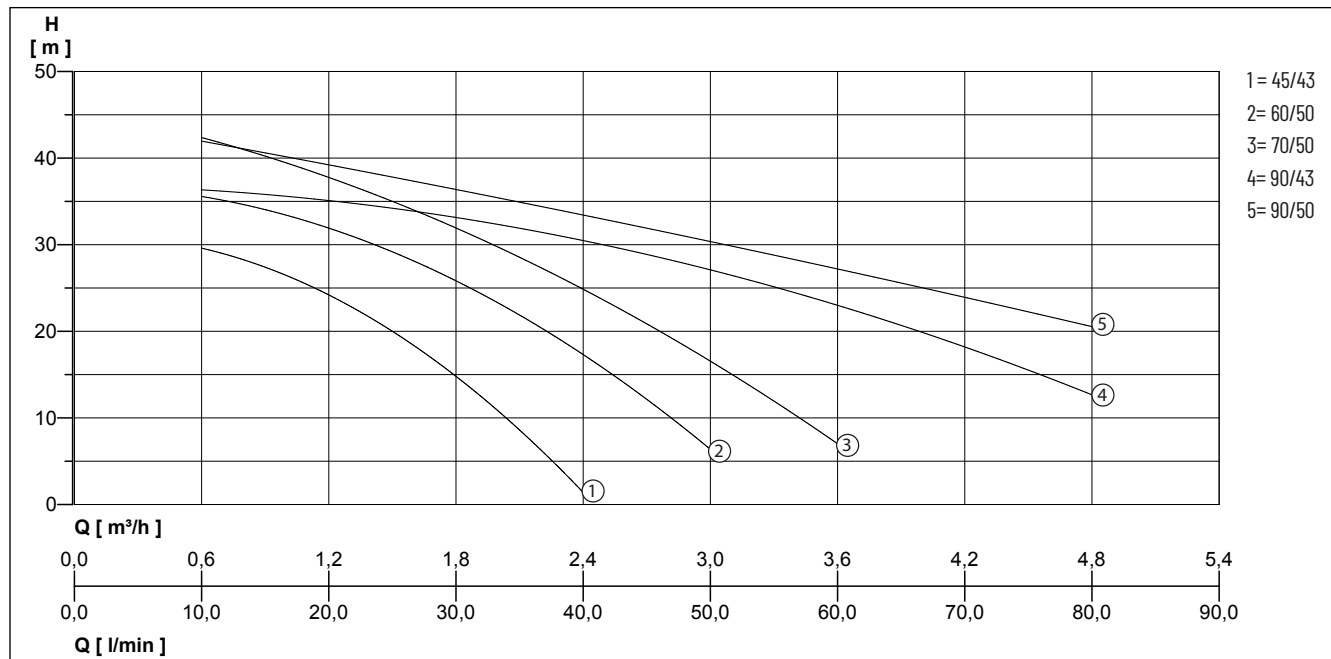

We reserve the right to change specifications without notice. Pump performance is subject to ISO 9906 ISO 9906:2012 - Grade 3B tolerances.

Type	Flow rate Q [m³/h]	0	0.6	1.2	1.8	2.4	3	3.6	4.2	4.8
JETINOX 45/43 M	Delivery head H [m]	43.0	30.0	23.0	16.0	1.0				
JETINOX 60/50 C/M		46.0	36.0	31.0	26.0	18.0	6.0			
JETINOX 70/50 C		48.0	42.5	37.5	32.0	25.0	16.5	7.0		20.0
JETINOX 70/50 M		48.0	42.5	37.5	32.0	25.0	16.5	7.0		10.0
JETINOX 90/43 C/M		43.0	38.0	34.0	32.0	29.0	27.0	25.0	21.0	10.0
JETINOX 90/50 C/M		50.0	42.0	39.0	37.0	33.0	30.0	27.0	25.0	20.0

JETINOX

SURFACE PUMPS - SELF-PRIMING

MECHANICAL DATA

Shaft	Stainless steel X 12 CrNiS 1809 (AISI 416)	Mechanical seal	Graphite
Impeller	Technopolymer with stainless steel shim ring	Counterface	Ceramic
Motor housing	Die-cast aluminium	Operating pressure max.	6 bar
Pump housing	Stainless steel X5 CrNi 1810 (AISI 304)	Type of liquid	clean water without suspended solids or abrasive material
Diffuser	Technopolymer	Temperature of the liquid max.	50 °C
		Saughöhe max.	8 m
		Gasket	NBR 70 shore

ELECTRICAL DATA

Voltage	1/N/PE~230 V	Ambient temperature max.	40 °C
Type of enclosure	IP 44	Rotation speed	2850 rpm
Insulation class	F		

JETINOX

Type	Code No.	Motor rating		Current	Plug	Weight
		P1	P2			
JETINOX 45/43 M	N4176190	0.6 kW	0.37 kW	3.0 A	Without	4.7 kg
JETINOX 60/50 C	N4176910	0.8 kW	0.55 kW	4.0 A	Safety	8.2 kg
JETINOX 60/50 M	N4176570	0.8 kW	0.55 kW	4.0 A	Without	8.2 kg
JETINOX 70/50 C	N4176900	1.0 kW	0.70 kW	4.5 A	Safety	9.5 kg
JETINOX 70/50 M	N4176760	1.0 kW	0.70 kW	4.5 A	Without	9.5 kg
JETINOX 90/43 C	N4176890	1.3 kW	0.75 kW	6.5 A	Safety	11.0 kg
JETINOX 90/43 M	N4176280	1.3 kW	0.75 kW	6.5 A	Without	11.0 kg
JETINOX 90/50 C	N4177020	1.5 kW	0.90 kW	7.0 A	Safety	13.0 kg
JETINOX 90/50 M	N4176500	1.5 kW	0.90 kW	7.0 A	Without	13.0 kg

JETINOX

SURFACE PUMPS - SELF-PRIMING

Version M

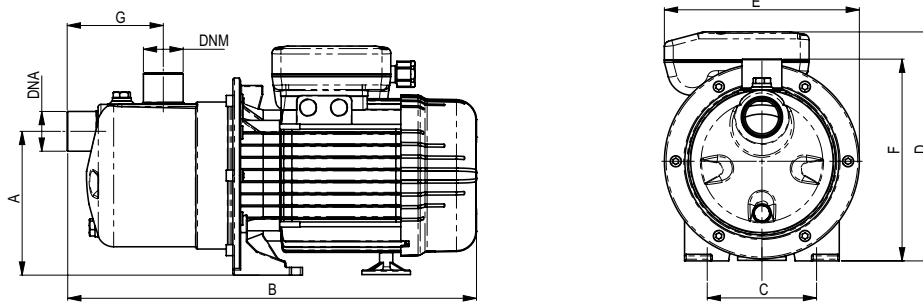

Version C (complete with handle, cable, schuko plug and switch)

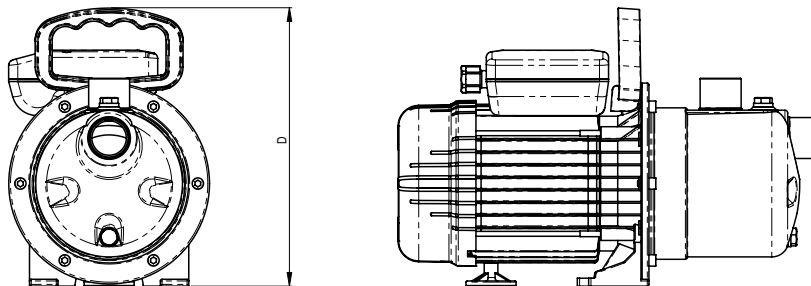

DIMENSIONS [mm]

Type	A	B	C	D	F	G	DNA	DNM	E
JETINOX 45/43 M	130	352	100	199	185	87	1"	1"	177
JETINOX 60/50 C	130	370	100	245	185	87	1"	1"	177
JETINOX 60/50 M	130	370	100	207	185	87	1"	1"	177
JETINOX 70/50 C	143	351	100	245	200	76	1"	1"	177
JETINOX 70/50 M	143	351	100	207	200	76	1"	1"	177
JETINOX 90/43 C	158	395	141	275	214	98	1 1/4"	1"	205
JETINOX 90/43 M	158	395	141	207	214	98	1 1/4"	1"	205
JETINOX 90/50 C	158	425	141	275	214	98	1 1/4"	1"	218
JETINOX 90/50 M	158	425	141	230	214	98	1 1/4"	1"	218

JETINOX

SURFACE PUMPS - SELF-PRIMING